

Yamato

VC3845P·2845P·2840P

Multi Needle Machines with Puller for Inserting (attaching) Elastic tape.

Elastic Inserting Process Has Been Improved With These Multi Needle Cylinder Bed Shape Machines!!

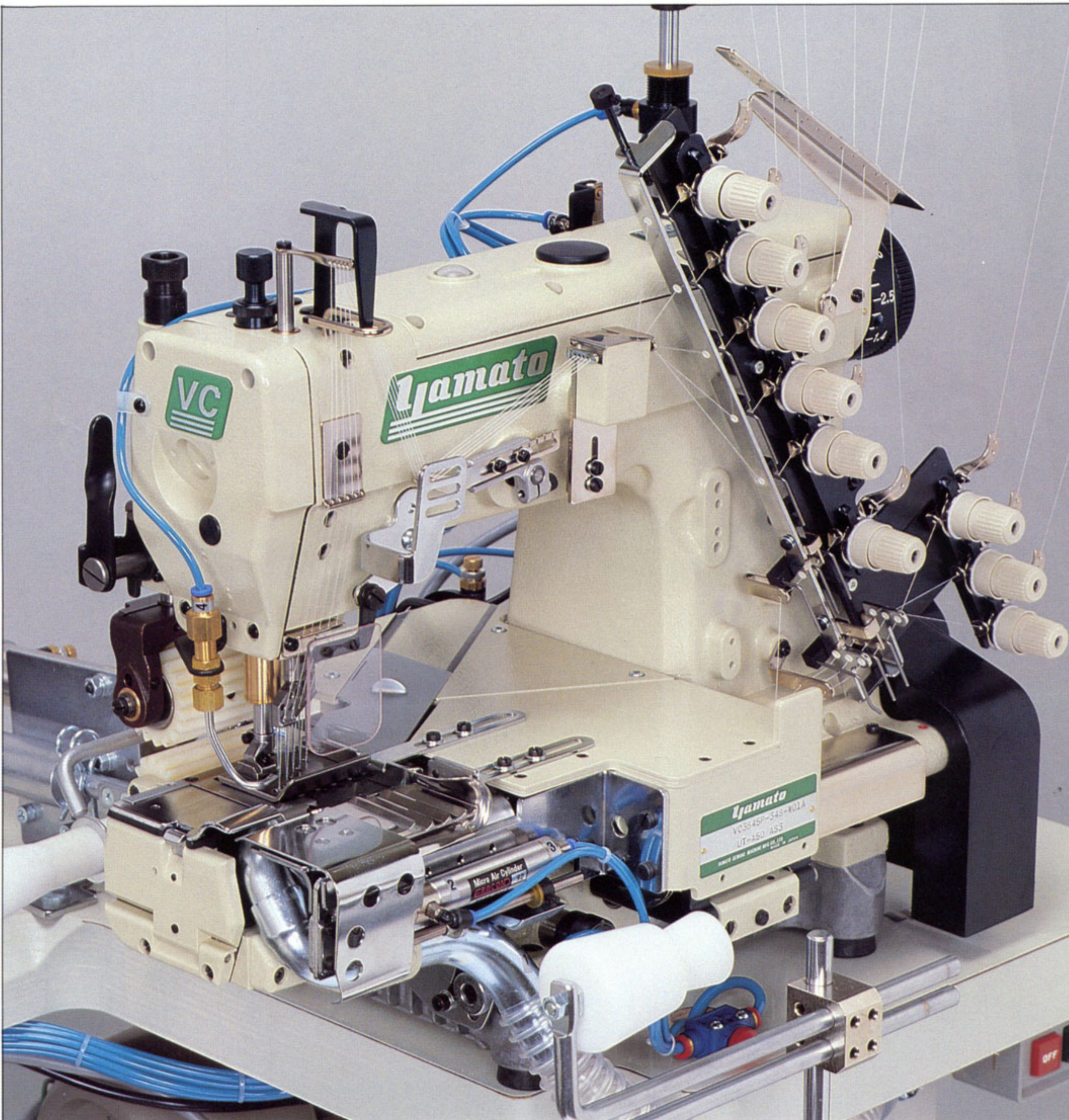

Yamato

VC3845P·2845P·2840P

Multi Needle Machines with Puller for Inserting(attach)Elastic tape.

Numbering on Model of Multi Needle Machines



- ① Symbol of Series
- ② Class No.
- ③ Multi Needle
- ④ Sub Model by use
 - 40 For hemming on sweat pants etc, on elastic preattached by overlock machines
 - 45 For inserting endless elastic tape to men's briefs, sweat pants etc. (tape width: up to 30mm)
- ⑤ Rear Puller
 - P indication=with Rear Puller
 - No indication=without Rear Puller
- ⑥ Needle distance
 - 348 = 34.8mm 188 = 18.8mm 308 = 30.8mm
 - 254 = 25.4mm 172 = 17.2mm 340 = 34.0mm
 - 303 = 30.3mm 280 = 28.0mm
- ⑦ Type of Needle Row
 - W...
 - X...
 - Y...
- ⑧ Pitch of Each Needle
- ⑨ Seam Style
 - A=
 - C=
 - E=
 - B=
 - D=
 - F=

Note B=Elastic is preattached by overlock machine in the preceding process.
- ⑩ Attachments
 - *UT-A50: Air-operated automatic under thread trimmer (with air-wiper)
 - *UT-A60: Same as above, but with AR10 Device
 - *AR10: Air-operated roller tension controller
 - *AS3: Air-operated automatic folder slider
 - Fabric Chip Collector (YV-2000) should be used for above machine.

Specifications										
Models										
VC3845P-348-W01A /UT-A60/AS3	5 (TV×5)	9	34.8 (4.8-10-10-10)	1.0~4.0	knob or lever	8 Max.	33	4,000	60 ℓ / min	
VC3845P-188-Y03C /UT-A50/AS3	4 (TV×5)	6	18.8 (4.8-10-4.0)	1.0~4.0	knob or lever	8 Max.	33	4,000	60 ℓ / min	
VC2840P-254-X02B /UT-A50	4 (TV×5)	8	25.4 (8.5-8.5-8.5)	1.0~4.0	knob or lever	8 Max.	33	4,000	60 ℓ / min	
VC2845P-254-X02D /UT-A50/AS3	4 (TV×5)	8	25.4 (8.5-8.5-8.5)	1.0~4.0	knob or lever	8 Max.	33	4,000	60 ℓ / min	

- **Air Wiper**
The moment UT-A50 works, air blows off thread tails away for the next sewing.
- **Left Hand Knife Mechanism**
Two-folded material edges can be cut and sewn simultaneously. Upper Knife stroke=6.0mm~10.0mm (adjustable by lever)

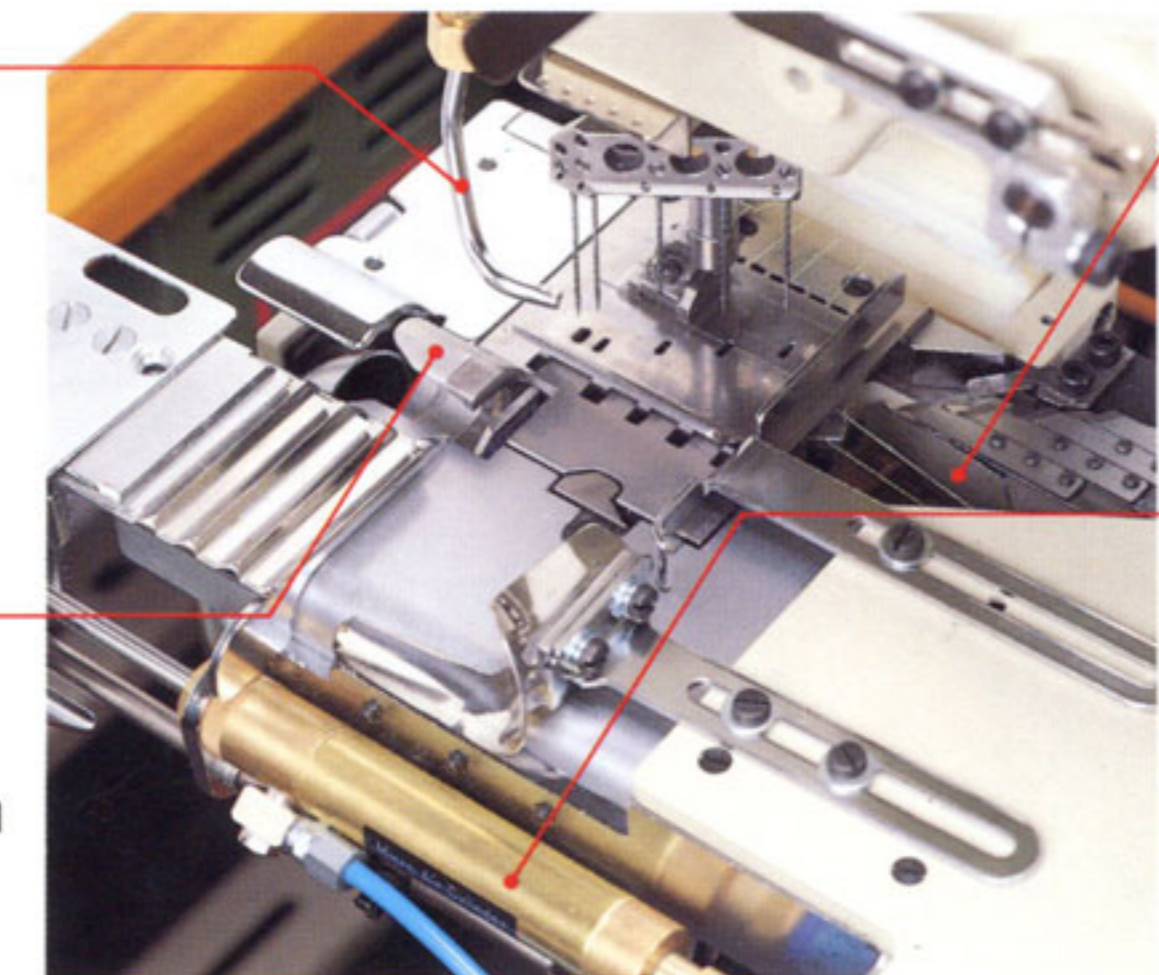

- **UT-A50**
[Air Operated Automatic Thread Trimmer]
It cuts off all the thread by depressing the pedal.
- **UT-A60**
Same as above, but with AR10 Device.
- **AS3**
[Air Operated Folder Slider]
By a soft touch of knee switch, it slides and then open and close automatically. It makes elastic setting easier.

Specification and appearance on this catalogue are subject to change without notice. For correct handling of products described on this catalog, please read instructions carefully before operation.

YAMATO SEWING MACHINE MFG. CO., LTD.
YAMATO WEB SITE URL: <http://www.yamato-sewing.com>

HEAD OFFICE
4-12, 4-CHOME, NISHI-TENMA, KITA-KU, OSAKA, 530-0047, JAPAN
TEL: +81-6-6364-5621 FAX: +81-6-6364-7185
E-mail: export-dept@yamato-sewing.com

YAMATO U.S.A. INC. (Head Office) 3485 LAKEMONT BLVD, FORT MILL, SC 29715 U.S.A. Tel: +1-803-548-0334 Fax: +1-803-548-0405	YAMATO MEXICO OFFICE C/O CASA DIAZ DE MAQUINAS DE COSER, S.A. DE C.V. FRAY SARVANDO TERESA DE MIER NO. 29, COLONIA OBRERA MEXICO D.F. C.P. 068000 Tel: +52-55-5764-9090 Fax: +52-55-5578-1470	YAMATO EUROPE GmbH. HAMBURG-FREEPORT AFRIKASTRASSE 4 D-20457 HAMBURG GERMANY Tel: +49-40-355347-0 Fax: +49-40-354371 E-mail: sales@yamato.de	YAMATO (HONG KONG) CO., LTD. RM. 1417, TUNG YING BLDG., 100 NATHAN ROAD, KOWLOON, HONG KONG Tel: +852-2721-0251 Fax: +852-2723-0444 E-mail: yamato@yamato-sewing.com.hk
YAMATO SINGAPORE PTE. LTD. 6 HARPER ROAD #03-01, LEONG HUAT BLDG., SINGAPORE 369674 Tel: +65-287-1955 Fax: 65-287-1028 E-mail: yamato@cyberway.com.sg	YAMATO SINGAPORE PTE. LTD. India liaison office NO.7, VALAVANKADU MAIN ROAD, C.K.P. LAYOUT OPP. P.K.G. COMPLEX, KUMAR NAGAR, TIRUPUR 641602 INDIA Sales-HP: +91-98430-60310, Service-HP: +91-98422-58584 Fax: +91-422-388-107 E-mail: yamatoindia@rediffmail.com	YAMATO SEWING MACHINE (NINGBO) CO., LTD. WEST HENGSHAN RD. BEILUN, NINGBO, ZHEJIANG PROVINCE, P.C. 315800 CHINA Tel: +86-574-8680088, 86800508 Fax: +86-574-86877326, 86800555 E-mail: yamato-china@yamato-sewing.com	YAMATO SEWING MACHINE MFG. CO., LTD. QINGDAO OFFICE SUNSHINE TOWER 2807, 61, XIANG GANG ROAD, QINGDAO, CHINA ZIP 266071 Tel: +86-532-5783175 Fax: +86-532-5783172



VC3845P·2845P·2840P

VC class Multi Needle Machines for Inserting(Attaching)Elastic Tape

These cylinder bed shape multi needle machine ensure, with speed and ease, firm and beautiful inserting (attaching) of elastic tape.



VC3845P-348-W01A/UT-A60/AS3

Super High Speed, Small Cylinder Bed, Multi Needle Machine with puller and with "Left Hand Knife" Trimming Mechanism For Inserting Elastic Tape

YAMATO's original "LEFT HAND KNIFE" cuts the left side edge of folded material cloth while sewing. Therefore serging operation is eliminated and beautiful finish with uniform edge of material is ensured. This machine sews and inserts preclosed elastic in one operation to the waist of underpants, sweat pants or the like. By only setting elastic on the supplementally roller and setting body material then putting the hands lightly, uniform and beautiful sewing can be obtained. At the finish of sewing, all the threads are trimmed by heeling down the pedal and then air wiper works. (UT-A50)

- *UT-A50: Air-operated automatic under thread trimmer (with air-wiper)
- *UT-A60: Same as above, but with AR10 Device
- *AR10: Air-operated roller tension controller
- *AS3: Air-operated automatic folder slider
- Fabric Chip Collector (YV-2000) should be used for above machine.

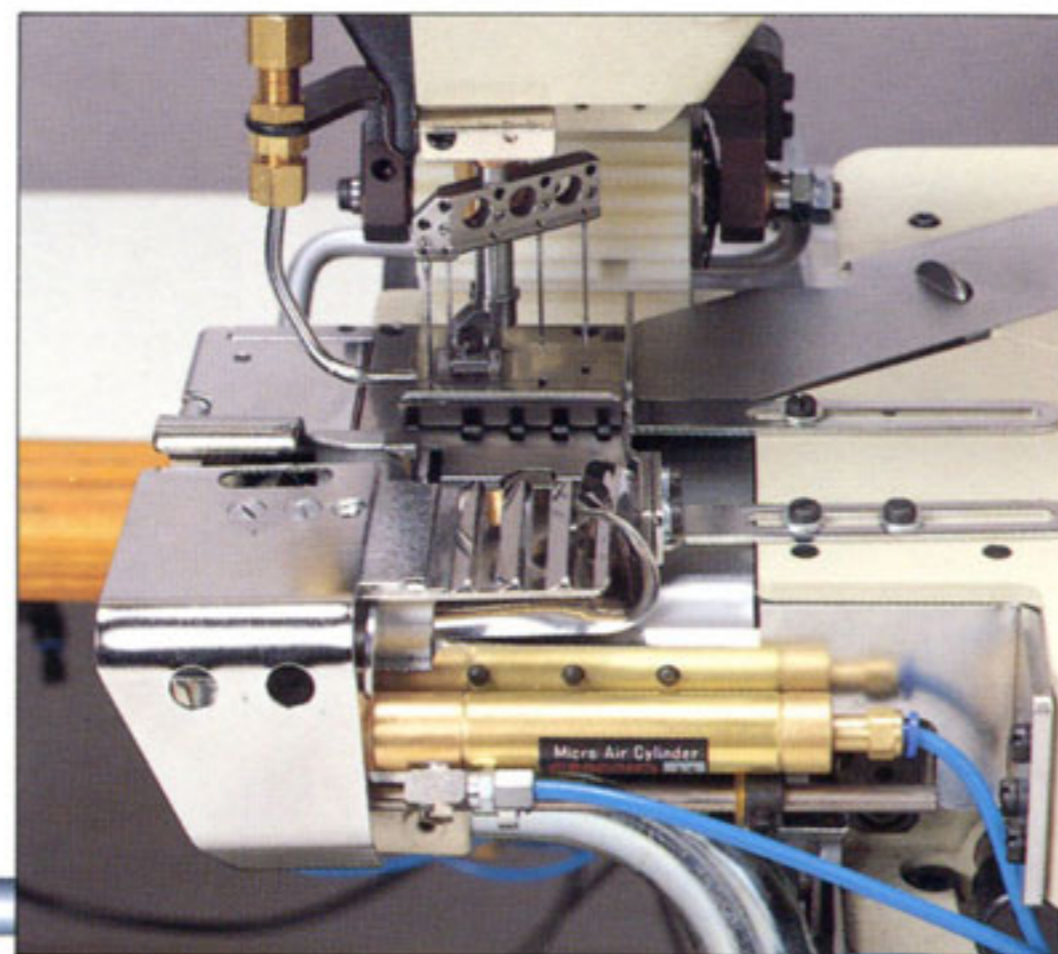
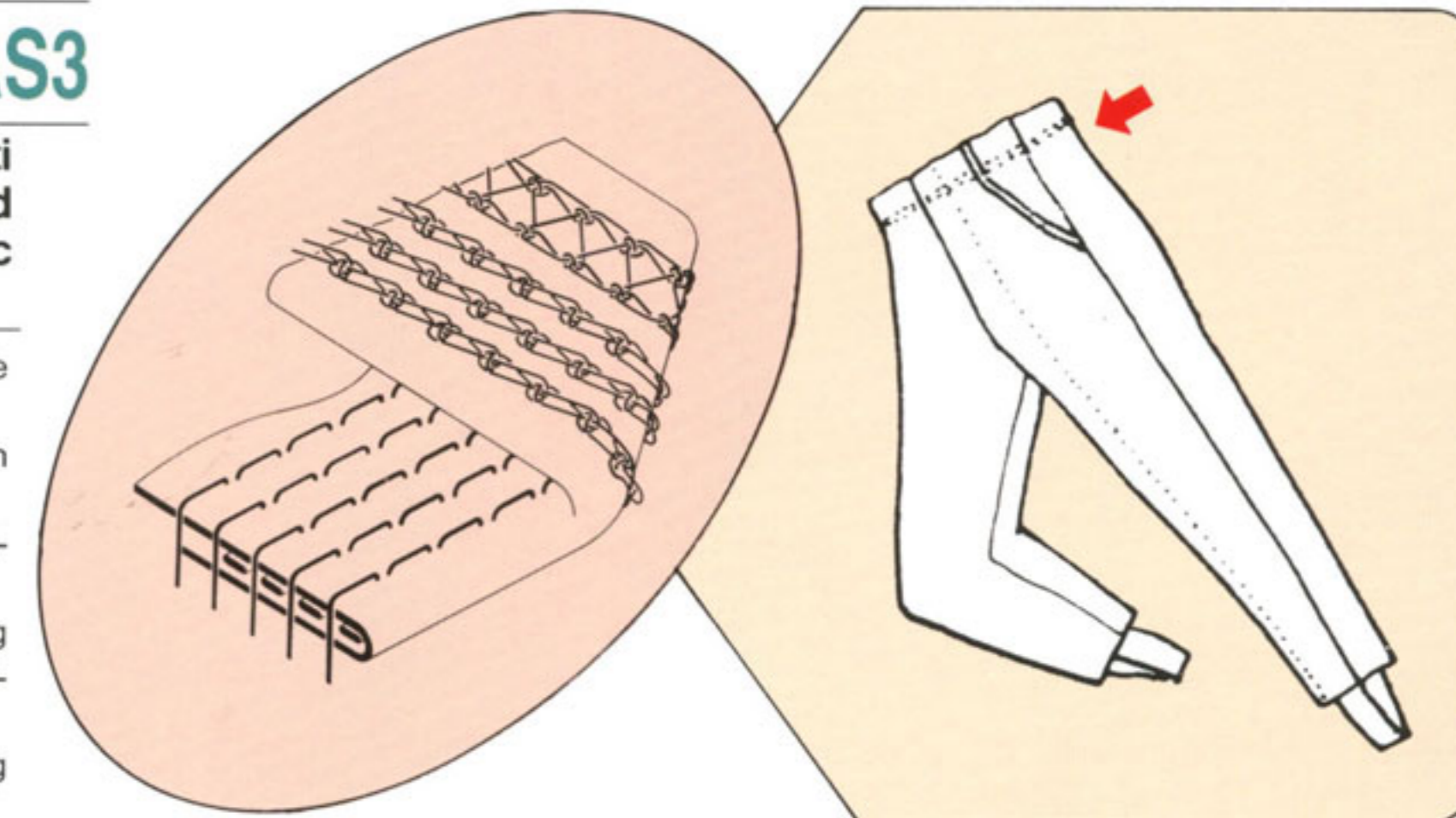

VC3845P-188-Y03C/UT-A50/AS3

High Speed, Small Cylinder Bed, Multi Needle Machine with Puller and with "Left Hand Knife" Trimming Mechanism

This multi needle machine sews 2 rows of 2 needle flat seams without top covering. Performs hemming and simultaneously inserting 2 elastic tapes. Besides, its Left Hand Knife Mechanism helps speedy operation. Suitable for attaching elastic to men's brief, drawers, etc.

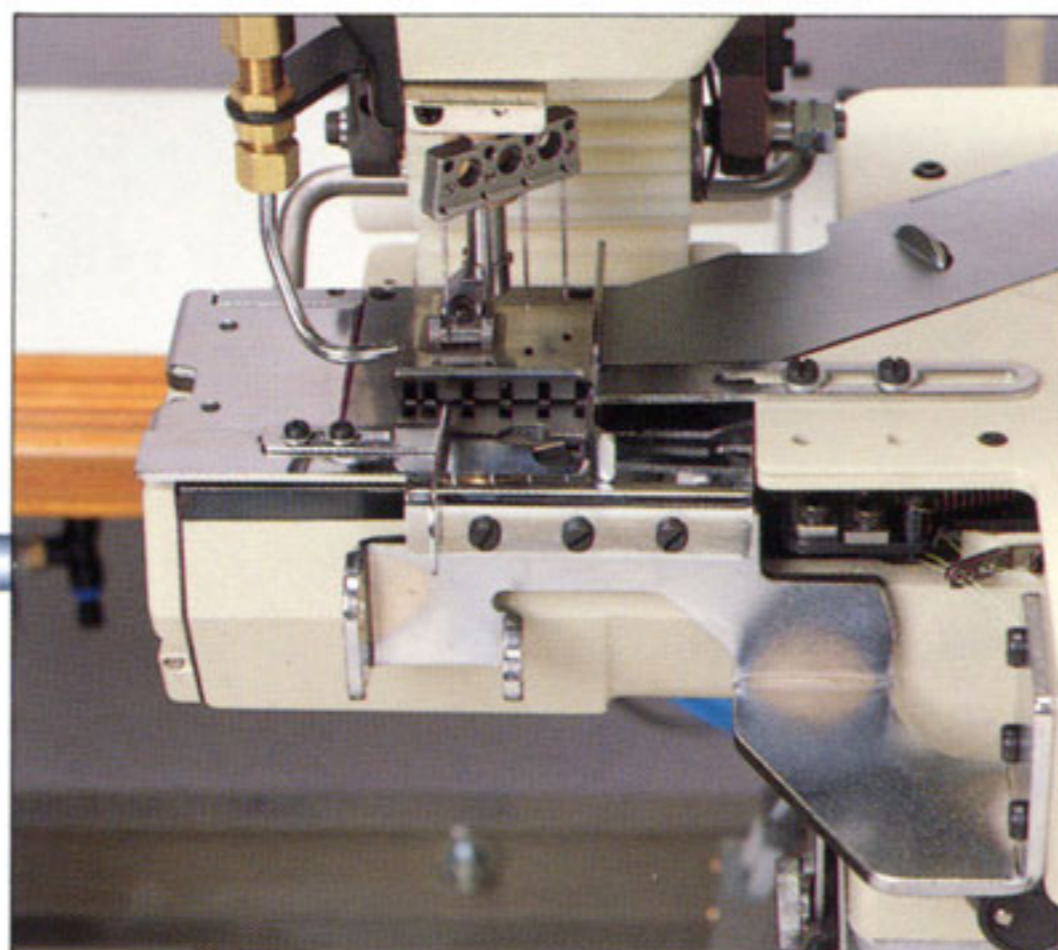
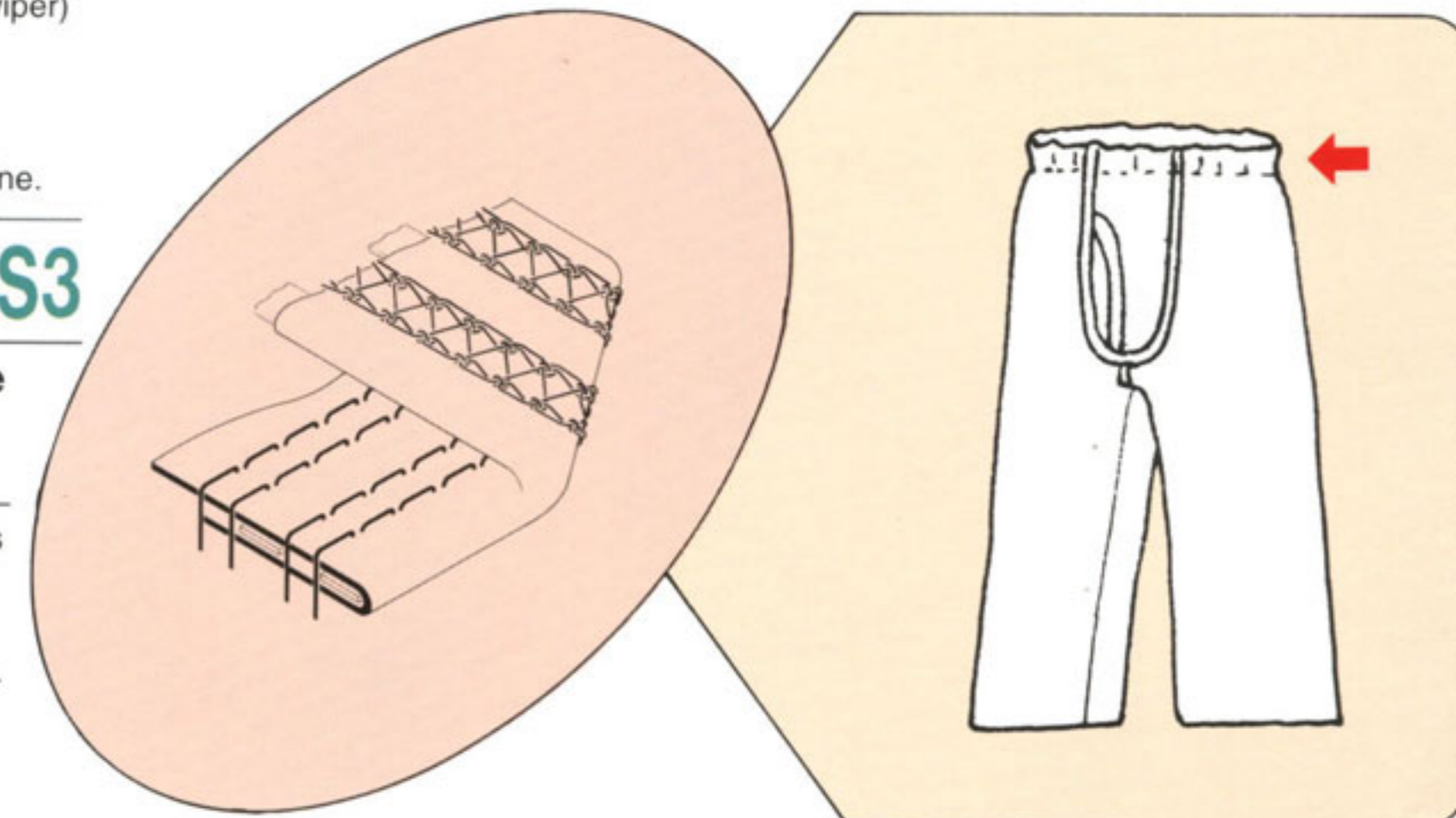

VC2840P-254-X02B/UT-A50

Super High Speed, Cylinder Bed Shape, Multi Needle Machine with Puller

This type of machine sews 4 rows of double chainstitch seams. Used for the 2nd process after overlock machine has attached woven elastic tape. Optimum for attaching elastic to the waist part of sweat pants, babies' and children's wears. Features folder slider to increase efficiency in production.

UT-A50 Air Operated Automatic Thread Trimmer

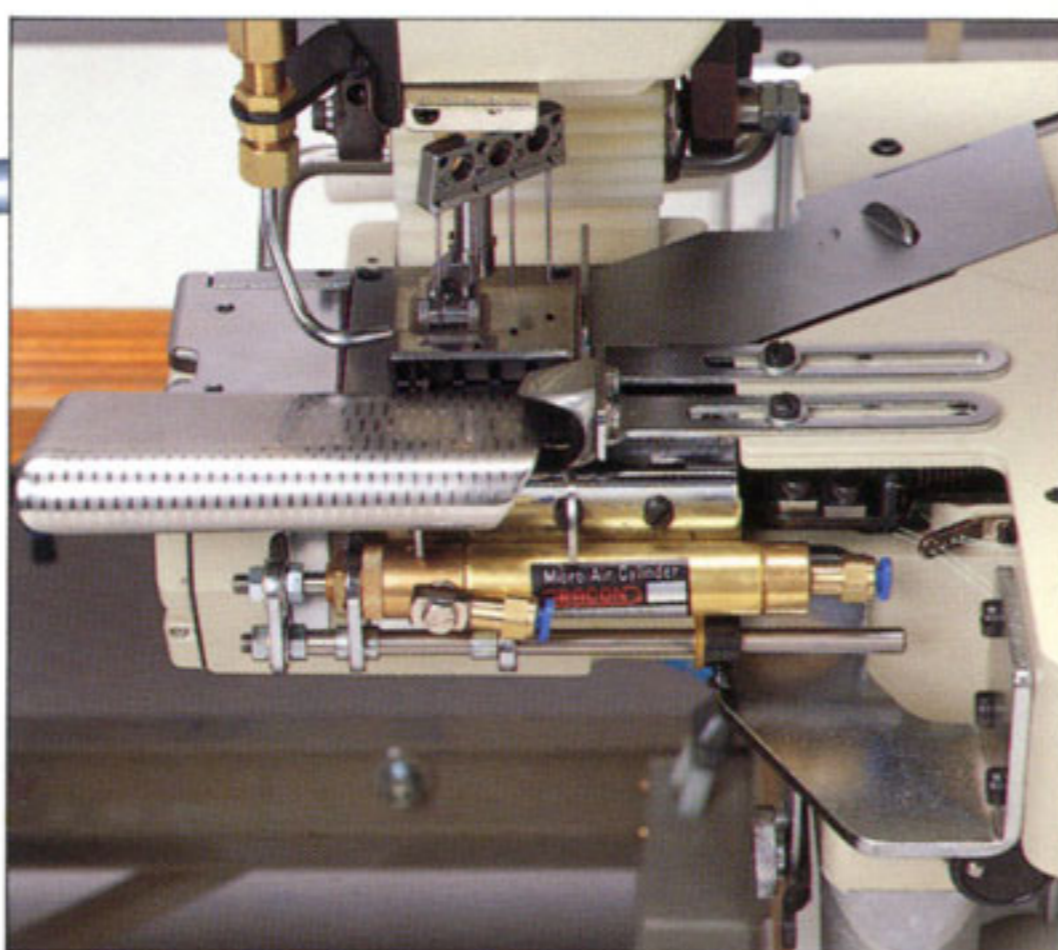
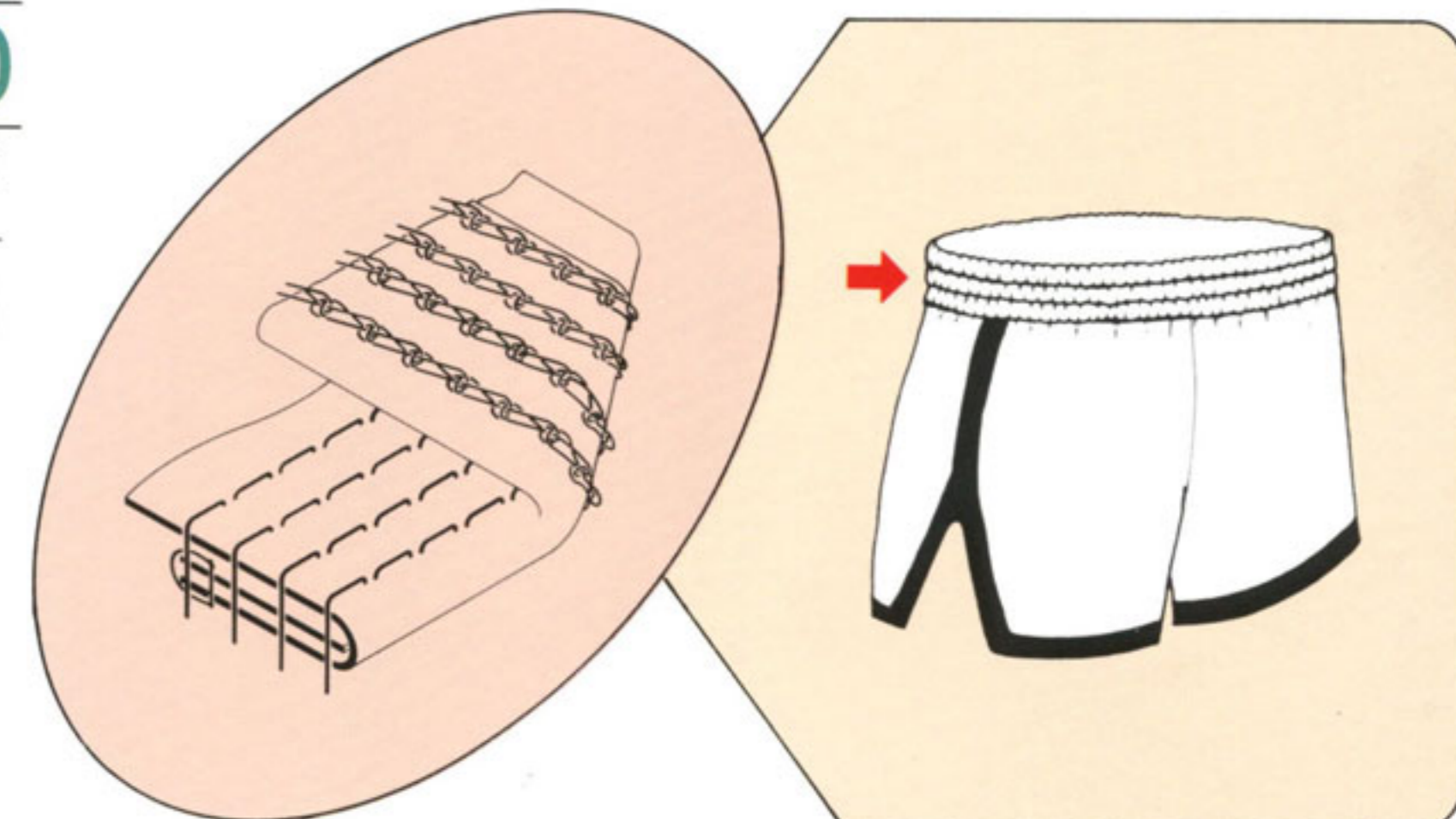

VC2845P-254-X02D/UT-A50/AS3

Super High Speed, Small Cylinder Bed, Multi Needle Machine with Puller

This machine attaches endless woven elastic under bodies. Equipped with unique Folder Slider that reduces frictional resistance. So tubular sewing on small garments can be speedily performed.

