

**Yamato**

# AZF<sup>8403</sup>/<sub>8420</sub>/K2/RS25

Cylinder Bed Shape, Overlock Machine with variable top feeder for attaching collar

**Yamato**

# AZF<sup>8403</sup>/<sub>8420</sub>/K2/RS25

Cylinder Bed Shape, Overlock Machine with variable top feeder for attaching collar

## Numbering on Model

### AZF8403-O4DF/K2/RS25



- ① Symbol of Series
- ② Class No. : 84= Cylinder Bed Overlock Machine
- ③ Submodel : 03= For single needle general seaming  
20= For 2 needle general seaming
- ④ Needle distance : O= 1 needle, X= 2.0mm, Y=2.4mm
- ⑤ Overlock width : 3=3mm, 4=4mm, 5=5mm
- ⑥ Feeding mode :  
D= both positive & negative differential available
- ⑦ Shape of knife:  
F= flat knife A= angled knife
- ⑧ Devices : K2=automatic thread chain trimmer (vertical type · direct drive)
- ⑨ RS25 : labor saving device for attaching neckband

## Submodels & Specifications

Model	Seam	Needle	Collar	Feeding	Knife	Devices	Feeding mode	Overlock width	RS25	Speed
AZF8403		DC×27 1	3	—	3 4	1~32		10B~123	9	6,500
AZF8420		DC×27 2	4	2.0 2.4	4 5				7	6,500

RS25	Min.	Max.
Circumference of garments	400mm	1,050mm
Width of 2- folded band	20mm	65mm

※With servo motor ; needles can be rested at the upper dead point so that collar can be set on the right side of needle drop part.

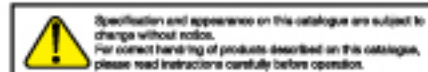

**YAMATO AZF8403/K2/RS25**



ISO9001:2008  
JQA-QM6412

**YAMATO SEWING MACHINE MFG. CO., LTD.**  
http://www.yamato-sewing.com

**HEAD OFFICE**  
4-12, 4-CHOME, NISHI-TENMA, KITA-KU, OSAKA, 530-0047, JAPAN  
TEL:+81-6-6364-5521 / FAX:+81-6-6364-7185 / E-mail:export-dept@yamato-sewing.com

YAMATO U.S.A. INC. TEL:+1-803-548-0334/FAX:+1-803-548-0405  
YAMATO EUROPE GmbH. TEL:+49-40-355347-0/FAX:+49-40-354371/E-mail:sales@yamato.de  
YAMATO (HONG KONG) CO., LTD. TEL:+852-2721-0251/FAX:+852-2723-0444/E-mail:yamato@yamato-sewing.com.hk  
雅瑪特(香港)有限公司 香港代表處 TEL:+86-769-86231363/FAX:+86-769-86231362  
大和縫紉機(寧波)有限公司 TEL:+86-574-86800518,86800558/FAX:+86-574-86800555/E-mail:marketing@yamato-china.com  
大和縫紉機製造株式會社 青島事務所 TEL:+86-532-85783175/FAX:+86-532-85783172  
大和縫紉機製造株式會社 上海事務所 TEL:+86-21-54400017,54400019/FAX:+86-21-54400021  
YAMATO SINGAPORE PTE LTD. TEL:+65-6287-1955/FAX:+65-6287-1028/E-mail:sales@yamato-sewing.com.sg  
M/S. YAMATO SINGAPORE PTE LTD., INDIA LIAISON OFFICE (TIRUPUR BRANCH) TEL:+91-421-4333701/FAX:+91-421-4333702/E-mail:yamato-sewing@airtelbroadband.in  
M/S. YAMATO SINGAPORE PTE LTD., INDIA LIAISON OFFICE (DELHI BRANCH) TEL:+91-11-41603280/FAX:+91-11-40574681  
YAMATO SINGAPORE PTE LTD., CUSTOMER SERVICE CORRESPONDENT IN JAKARTA, INDONESIA FAX:+62-21-781-8727  
YAMATO SINGAPORE PTE LTD., BANGLADESH LIAISON OFFICE TEL:+88-02-899-1864/FAX:+88-02-899-1865  
YAMATO MEXICO OFFICE TEL:+52-55-5764-9090/FAX:+52-55-5578-1470  
THE RESIDENT REPRESENTATIVE OFFICE OF YAMATO SEWING MACHINE MFG. CO., LTD IN HO CHI MINH CITY TEL:+84-8-62968057/FAX:+84-8-38113384

*The well-reputed AZF8400 type complete cylinder bed overlock machine with variable top feeder. There is no obstruction at all under and rear of cylinder bed so sewing tubular garment is smooth. Moreover, combined with RS25 Device, it promises stable quality in the production of cuffs, neck & waist of T-shirts or sweat shirts - especially suitable for attaching collar.*

**YAMATO AZF8400**

YAMATO AZF8400 has complete small cylinder bed (circumference : 151.5mm). Stitch length can be changed by push-button and differential feed amount by lever. Moreover, movement of top feeder is correctly adjustable by Micro Adjuster. The main advantage is that the top feeder is designed to draw complete ellipse just as bottom feeder does - with our unique direct drive mechanism. So no scratch by feed dog will be found on any thin and delicate material.



**Full speed operation for any process**

No need to reduce sewing speed even in top gathering or sewing heavy weight material.

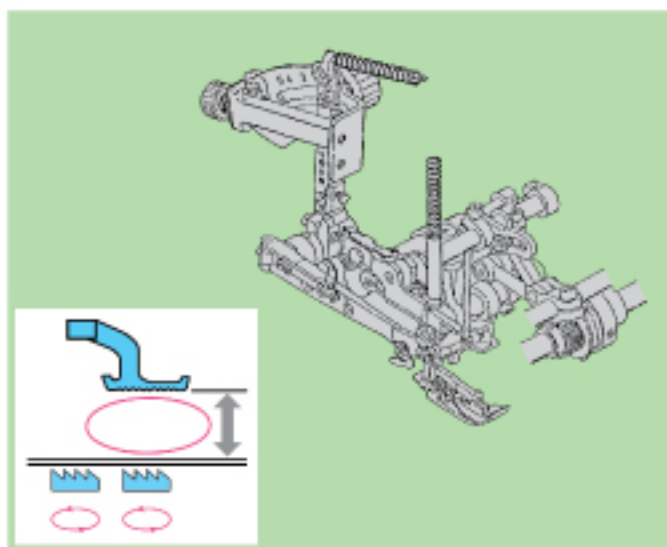

**YAMATO RS25 will satisfy you with uniform finish of collar.**

YAMATO RS25 Device, with AZF8403/K2 or AZF8420/K2, will be a great help for operators in charge of attaching collars to T-shirts or sweat shirts.

RS25 allows you to :

- ① eliminate burst of seam as fabric holder guides fabric firmly.
- ② attach collar (waistband) in uniform width thanks to holder which folds them correctly in half.
- ③ finish band flatly, which enhances appearance & quality of garments.

Besides, AZF8403 or AZF8420 can attach small tubular bands to cuffs or ankles on the cylinder bed by swinging out the device.

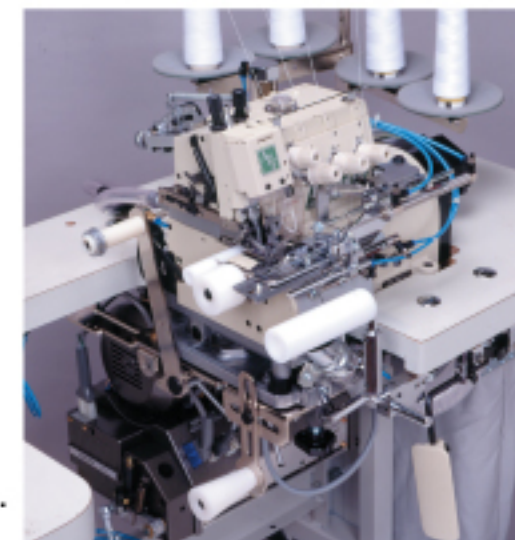

**Information on production (ex.)**

(allowance rate:20%)

Production line	No. 1	No. 2	No. 3
Conventional collar attaching operation	32 sec. (900 pcs./8 hrs.)	44 sec. (655 pcs./8 hrs.)	39 sec. (738 pcs./8 hrs.)
YAMATO AZF8403/K2/RS25	28 sec. (1,029 pcs./8 hrs.)	32 sec. (900 pcs./8 hrs.)	35 sec. (823 pcs./8 hrs.)
Save time	4 sec.	12 sec.	4 sec.
Productivity	114% (+129 pcs.)	137% (+245 pcs.)	112% (+85 pcs.)

Simple mechanism without electronics to open and close folder (patent pending).

RS25 includes air-operated holder (A) & (B), air-operated presser foot lifter (C), air-kit (D) for thread chain trimmer <K2>, and dust collector (E).

